

9800.72.007 MR661



For industrial, R&D, Testlabs

- ➔ **Heavy Duty version for indoor and outdoor application**
- ➔ **Absolut EMI/RFI Immune**
- ➔ **100% passive Sensor, no metal, no electric inside**
- ➔ **Huge Frequency range**
- ➔ **High responsibility and environment friendly**
- ➔ **Signal transfer over 200m**

Description

The fibre optical Acceleration Sensor is built with non-metallic parts, especially for application which metals are not aloud. These Sensor are built with an IP67 protection for using indoor as well outdoor. Ideal for using in Industrial as well on big machines to measure the vibration during the process. The housing is build 100% in ceramic for working in EMV fields. A micromembrane records an acceleration and send them to a optical head into light signal (density modulation). A glassfibre could transmit the signal over 200m to the remote controller unit which transform the optical signal into as standard AC signal.

The construction is simple build trough this the sensor is very robust and works well under all environments.

Application, Benefit

There are several field of application for fibre optical acceleration sensor. For example End winding, controlling of stock, detection of micro movement in high voltage application. Operation under HF for measurement under antennas and system are also possible. With the heavy duty design the sensor are also working in high explosive areas like mining, refinery, the Sensor is classified as „Simple Apparatus“ after IEC 60079-28 (inherently safe optical radiation). With this the sensor is approved for ATEX Group I and II as well all categories gas and dust.

Standards

ATEX Equipment Group I (Mining); all categories (M1 und M2) Gas und dust.
NEC 500 class 1,2,3 NEC 505 Zone 0,1,2,20,21,22
MTBF > 100'000 hours
CE-conform after EN 61000-6-1, EN 61000-6-4, EN 61000-6-3 and EN 6100-4-8
RoHS-conform after EG-standard 2002/95/EG
Produced under ISO 9001-2015
Protection after EN 60529
ATEX II 3G mb IICT4 after EN 60079-0 and EN60079-18

Technische Änderungen vorbehalten Date: 15.11.2018

9800.72.007 MR661



9800.72.004 MR661 – 2 Axis Acceleration Sensors

Frequency range	1-1000Hz
Max. Acceleration	50g (0-50g peak)
Noise Density (micro-g/Hz)	<100
Signal output direct proportional to acceleration	100mV/g pk-pk
Temperature Range	-40°C bis 200°C
Protection	IP67
Material Sensor head	ceramically
Material Cable	PEEK/PTFE
Optical Connection	FO4
Fibre Length	6m
Type of Fiber	100/125/250 mikron
Isolation of Sensor to electronic	65kV RMS
Magnetically immunity	100%

Dimensions

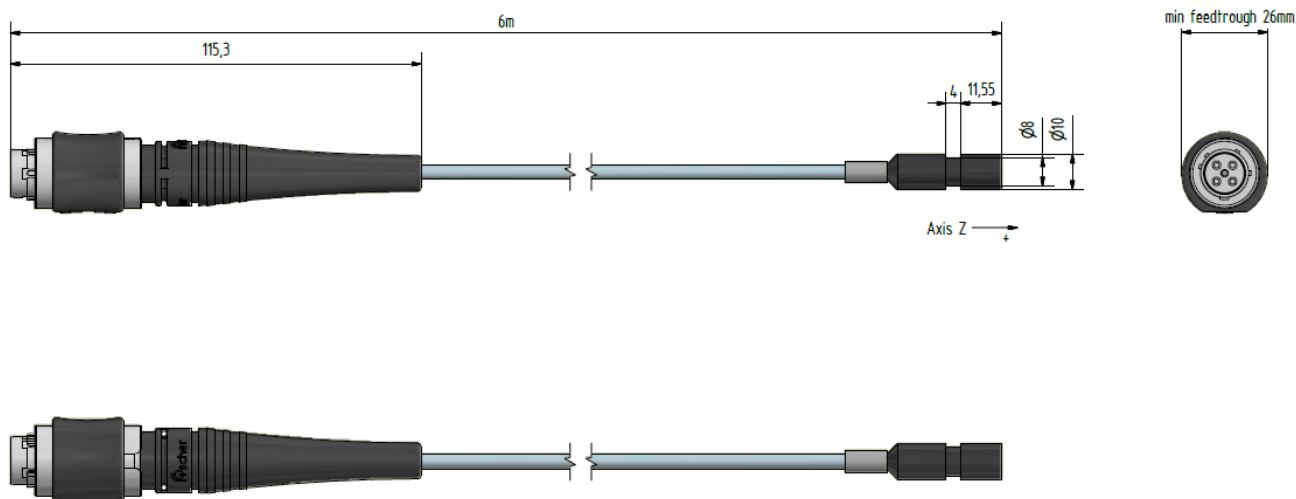

Order code

	9800.72.004	MR661- 1 Axis Acceleration sensor with 6m Fibre and FO4 Connector
--	--------------------	--



Questions?

Call: +41 (0)44 843 40 20 or Mail: sales@micronor.ch

Technische Änderungen vorbehalten Date: 15.11.2018